

ANALYSIS OF SQUARE COMMUNICATION GRIDS VIA INFINITE PETRI NETS*

АНАЛІЗ КВАДРАТНИХ КОМУНІКАЦІЙНИХ ГРАТОК НЕСКІНЧЕННИМИ СІТЯМИ ПЕТРІ*

АНАЛИЗ КВАДРАТНЫХ КОММУНИКАЦИОННЫХ РЕШЕТОК
БЕСКОНЕЧНЫМИ СЕТЯМИ ПЕТРИ*

Summary. A technique of the linear invariants calculation for infinite Petri nets with the regular structure was presented and studied on the example of square communication grids of an arbitrary size. Linear systems of equations for the calculation of p -invariants and their solutions were constructed in parametrical form. The consistent firing sequence for proof of t -invariants was constructed, it contains all the transitions of the net on the base of the loop of the transmission graph which contains all its arcs. It was grounded that the compulsory buffering of the packets inevitably leads to possible blockings of communicating devices. The structure of complex deadlocks involving an arbitrary number of communicating devices caused by both the cycle of blockings and the isolation was studied.

Анотація. Надано методику обчислення інваріантів для нескінченних сітей Петрі з регулярною структурою на прикладі квадратних комунікаційних ґраток довільного розміру. Системи лінійних алгебраїчних рівнянь для знаходження p -інваріантів і отримані розв'язки подані у параметричному вигляді. Запропонована нова методика конструктивного доказу t -інваріантності на основі побудови базисних циклів спрацьовування переходів. Обґрунтовано, що примушена буферизація пакетів приводить до блокування телекомунікаційних пристроїв. Вивчено структуру складних тупиків, що містять довільну кількість комунікаційних пристроїв, зумовлених циклом блокувань та ізоляцією пристроїв.

Аннотация. Представлена методика вычисления инвариантов для бесконечных сетей Петри с регулярной структурой на примере квадратных коммуникационных решеток произвольного размера. Системы линейных алгебраических уравнений для нахождения p -инвариантов и полученные решения представлены в параметрическом виде. Предложена новая методика конструктивного доказательства t -инвариантности на основе построения базисных циклов срабатывания переходов. Обосновано, что принудительная буферизация пакетов приводит к блокировке телекоммуникационных устройств. Изучена структура сложных тупиков, содержащих произвольное число коммуникационных устройств, вызванных циклом блокировок и изоляцией устройств.

The problem of verification of grid structures with an arbitrary number of attached devices is prospect line of investigation. The Petri net application for the verification of telecommunication protocols is a rather traditional direction of research [1, 2]. The majority of known works study communication processes in pairs of communicating devices. But anomalies may occur which involve an arbitrary number of communicating devices and the present paper proves this statement.

As the number of communicating devices and the structure of the network are varying considerably for real-life networks, a technique is required that could manage an arbitrary number of devices constituting an arbitrary structure. Recently the parametric composition of functional Petri nets [3] was applied for the analysis of infinite linear structures [4] of communicating devices. A simpler direct approach [5] was applied for treelike infinite structures but the solution for an arbitrary structure is not produced.

The purpose of present work is analysis the square communication grids (matrix) infinite structure of communicating devices but it seems that the obtained results might be generalized for an arbitrary structure as well.

1. The Models Construction. For the composition of infinite communication structures, submodels of a typical communication device and a terminal device are required. Further we compose such a regular communication structure as a square matrix of communicating devices of an arbitrary size.

1.1. The Model of a Communication Device. Let us consider such real-life communication devices as switches and routers, for instance, Ethernet switches and IP/MPLS routers. Their basic function [6] is the redirection of the arrived packets to the destination port. So the model of a communication device consists of ports models. Usually each port works in the full-duplex mode that allows simultaneous transmission in both directions. This is provided by the different channels of the port: the input channel and the output channel. A

* Work supported by NATO grant ICS CLG 982698

channel of a port has its internal buffer for the allocation of one packet. Moreover, the communication device uses an internal buffer with the limited capacity where it stores the packets before they are put into the destination port. The usage of the switching and routing tables is not modeled but the redirection function is represented by the allocation of the arrived packet for each possible destination. This abstract description suits the routers operation with the compulsory buffering of the packets and without the cut-through possibilities [6].

The constructed model of a communication device is represented in Fig. 1a. It has four ports for the further composition of the communication matrix but it might be constructed with an arbitrary number of ports as well. All the ports are situated on the sides of a square and are numbered clock-wise from 1 (the upper side) to 4 (the left side). A port consists of two channels: input (*i*) and output (*o*). Each channel is represented by a pair of places: one for the packet allocation and the other for modeling the port buffer capacity which is equal to 1. For instance, port 1 is modeled by the following places: p_{1i} – input buffer; p_{1il} – limitation of the input buffer capacity (equal to 1); p_{1o} – output buffer; p_{1ol} – limitation of the output buffer capacity (equal to 1). The internal buffer of the communication device is modeled by the separate places where the packets with the corresponding destinations are allocated: p_{b1} , p_{b2} , p_{b3} , p_{b4} . For instance, place p_{b1} stores the packets redirected to port 1. Moreover, the capacity of the internal buffer is modeled by place p_{bl} . The operation of the port output channel is represented by the only transition t^{*o} , for instance, t_{1o} for port 1. The transition checks the availability of the port buffer p_{1ol} , gets a packet from the corresponding place p_{b1} , puts the packet into the port output buffer p_{1o} and increases the capacity of the internal buffer p_{bl} . The operation of the port input channel is more sophisticated because it models the process of the destination choice. For each port it is modeled by three transitions ($3 = 4 - 1$). For instance, t_{1i2} , t_{1i3} , t_{1i4} for port 1. Transition t_{1i2} allocates the packets redirected from port 1 to port 2 into the internal buffer place p_{b2} and so on.

Notice that the constructed model constitutes a definite balance between the complexity of real-life devices and the possibilities for formal analysis. At least, the essential features [6] are modeled: redirection of the packets and their intermediate allocation into the internal buffer with the limited capacity.

1.2. The Model of a Communication Structure. The matrix (two dimensions) structure of communication devices is studied in the present paper. As the real-life communication structure may consist of an arbitrary number of communication devices, special methods should be developed that handle the infinite number of communication devices. Furthermore, it will be shown that the communication structure brings us anomalies which can not be found during the traditional study of communication processes in pairs of devices [1,2]. The results are obtained for the regular structures such as the matrix but it seems they might be generalized on arbitrary structures.

Notice that the constructed model $n2s1$ is a functional Petri net [3]. Let us construct a communication structure via the composition of communication device models situated in the cells of a matrix. Square matrices of the size k are studied, where k is an arbitrary natural number. So each device $R^{i,j}$ in the matrix is defined by two indices: i – for vertical direction and j – for horizontal, $i = \overline{1, k}$, $j = \overline{1, k}$. The matrix communication structure is represented in Fig. 1b.

The connection of communication devices is provided by the fusion (union) of corresponding contact places. For instance, for an internal communication device $R^{i,j}$, $i = \overline{2, k-1}$, $j = \overline{2, k-1}$, the places of port 1 are fused with the corresponding places of port 3 for the device $R^{i-1,j}$ in such a way that place $p_{1o}^{i,j}$ is fused with $p_{3i}^{i-1,j}$, place $p_{1ol}^{i,j}$ – with $p_{3il}^{i-1,j}$, place $p_{1i}^{i,j}$ – with $p_{3o}^{i-1,j}$, place $p_{1il}^{i,j}$ – with $p_{3ol}^{i-1,j}$. So the full-duplex mode of communication via two channels of the ports is modeled. The rules of device $R^{i,j}$ connection may be formulated in the following way: the upper side – port 1 to port 3, device $(i-1, j)$; the right side – port 2 to port 4, device $(i, j+1)$; the bottom side – port 3 to port 1, device $(i+1, j)$; the left side – port 4 to port 1, device $(i, j-1)$. After the composition, the contact places have duplicate names. To avoid duplicity, the names of the places for the ports 1, 4 (the upper and left sides) will be considered with respect to the current device, for the ports 2, 3 – with respect to the neighbor devices and their ports 1, 4 correspondingly. So the names of the fusion places have only the prefixes of the ports 1, 4. Moreover, to simplify further notations, the places of the right and bottom borders of the matrix are named with respect to non existing devices with the indices equaling to $k+1$. So the numbers of the ports 2 and 3 do not appear in the matrix. An example of the communication matrix (with attached terminal devices) for $k = 2$ is represented in Fig. 3.

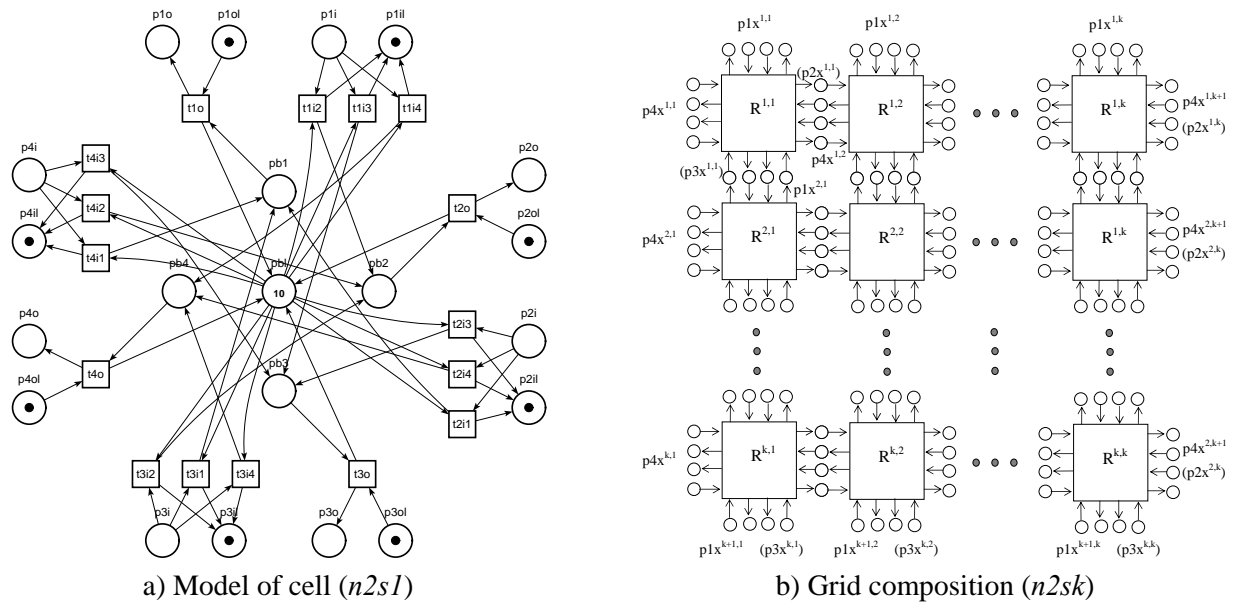

Figure 1 – Model of square grid communication structure

1.3. The Models of Terminal Devices. The communication devices may be attached to each other constituting a communication structure but they are created only for the packets transmission among the terminal devices: workstations and servers. In the present work, the client-server technique of interconnection is not studied, so the types of terminal devices are not distinguished as in [7]. An abstract terminal device provides at least two basic functions: send packet and receive packet. These basic functions are provided by the models represented in Fig. 2.

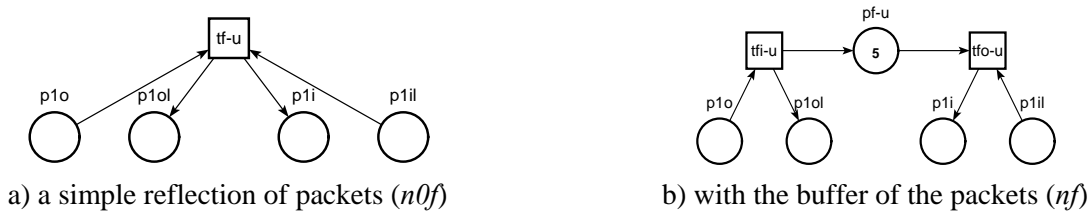

Figure 2 – Petri net models of a terminal device

The Fig. 2,a gives the simplest model that only reflects the arrived packets from the input to the output via transition $tf-u$; names of the places are given with respect to the places of a communication device port. So the model of a terminal device may be attached by the fusion of the places with the same names. The model in Fig. 2,b contains an internal buffer of the packets $pf-u$; transition $tfi-u$ models the input of the packets, while transition $tfo-u$ models the output. The suffix $-u$ means the upper row of terminal devices that supposes port 1 for attachment; the left, right and bottom (down) rows contains the suffices $-l$, $-r$, $-d$ correspondingly. An example of the communication matrix with attached terminal devices (type a) is represented in Fig. 3.

2. Calculating p-invariants. The described composition of the model allows the application of the technique for Petri net analysis via the composition of its functional subnets [3]. This approach was applied for the Ethernet protocols with the bus structure verification for an arbitrary number of devices on the bus (line structure) [4]. But it brings us the explosion of solutions basis for the composition system and hinders the application of this technique. A rather simple technique of the direct construction of an infinite linear system for p- and t-invariants applied for the switched Ethernet protocols verification (binary tree structure) [5] seems more adequate.

The following infinite linear system of equation is constructed for p-invariants calculation of Petri net $n2sk$ (Fig. 1b) – the matrix of k devices $n2s1$ (Fig. 1,a), where k is an arbitrary natural number:

$$\left\{ \begin{array}{l}
 t_{10}^{i,j} : x_{10l}^{i,j} + x_{b1}^{i,j} = x_{10}^{i,j} + x_{bl}^{i,j}, \\
 t_{1i2}^{i,j} : x_{1i}^{i,j} + x_{bl}^{i,j} = x_{1il}^{i,j} + x_{b2}^{i,j}, \\
 t_{1i3}^{i,j} : x_{1i}^{i,j} + x_{bl}^{i,j} = x_{1il}^{i,j} + x_{b3}^{i,j}, \\
 t_{1i4}^{i,j} : x_{1i}^{i,j} + x_{bl}^{i,j} = x_{1il}^{i,j} + x_{b4}^{i,j}, \\
 t_{40}^{i,j} : x_{40l}^{i,j} + x_{b4}^{i,j} = x_{40}^{i,j} + x_{bl}^{i,j}, \\
 t_{4il}^{i,j} : x_{4i}^{i,j} + x_{bl}^{i,j} = x_{4il}^{i,j} + x_{b1}^{i,j}, \\
 t_{4i2}^{i,j} : x_{4i}^{i,j} + x_{bl}^{i,j} = x_{4il}^{i,j} + x_{b2}^{i,j}, \\
 t_{4i3}^{i,j} : x_{4i}^{i,j} + x_{bl}^{i,j} = x_{4il}^{i,j} + x_{b3}^{i,j}, \\
 t_{20}^{i,j} : x_{4il}^{i,j+1} + x_{b2}^{i,j} = x_{4i}^{i,j+1} + x_{bl}^{i,j}, \\
 t_{2il}^{i,j} : x_{40}^{i,j+1} + x_{bl}^{i,j} = x_{40l}^{i,j+1} + x_{b1}^{i,j}, \\
 t_{2i3}^{i,j} : x_{40}^{i,j+1} + x_{bl}^{i,j} = x_{40l}^{i,j+1} + x_{b3}^{i,j}, \\
 t_{2i4}^{i,j} : x_{40}^{i,j+1} + x_{bl}^{i,j} = x_{40l}^{i,j+1} + x_{b4}^{i,j}, \\
 t_{30}^{i,j} : x_{1il}^{i+1,j} + x_{b3}^{i,j} = x_{1i}^{i+1,j} + x_{bl}^{i,j}, \\
 t_{3i1}^{i,j} : x_{10}^{i+1,j} + x_{bl}^{i,j} = x_{10l}^{i+1,j} + x_{b1}^{i,j}, \\
 t_{3i2}^{i,j} : x_{10}^{i+1,j} + x_{bl}^{i,j} = x_{10l}^{i+1,j} + x_{b2}^{i,j}, \\
 t_{3i4}^{i,j} : x_{10}^{i+1,j} + x_{bl}^{i,j} = x_{10l}^{i+1,j} + x_{b4}^{i,j}, \quad i = \overline{1, k}, \quad j = \overline{1, k}.
 \end{array} \right. \quad (1)$$

Notice that the standard technique of invariants calculation [8] is applied directly to the infinite Petri net. In the system for p-invariants calculation each equation corresponds to a transition; the sums of variables for the input and output places are equal. It is easy to check that each transition of the net $n2dk$ was considered in the system (1).

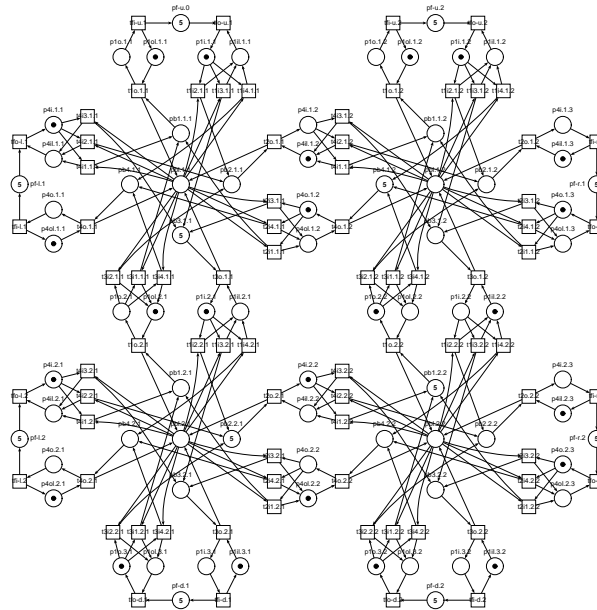

Figure 3 – Petri net model of a grid with attached terminal devices for $k = 2$ (n_f2s_2)

The first 4 equations correspond to the transitions of ports 1, the next 4 – to the transitions of ports 4. They use variables of the places with the indices of the current device (i, j) , according to the naming rules. The next 4 equations describe the transitions of ports 2; the last 4 equations – the transitions of ports 3. They use the variables of ports 1, 4 places with the indices of the neighbor device $(i+1, j)$, $(i, j+1)$ correspondingly, instead of ports 3, 2 places with the indices of the current device (i, j) , according to the naming rules. Let us count the number of the equations and variables in the system (1). The total number of equations (transitions): $N_k^{n2t} = 16 \cdot k^2$. The total number of variables (places): $N_k^{n2p} = 13 \cdot k^2 + 8 \cdot k$.

The universal methods for the infinite systems of the linear equations under the rings (integer numbers) solving, especially into semigroups (nonnegative integer numbers) are unknown. We applied a

heuristic method of a general solution construction in the parametric form. The general solution of the system (1) may be represented as:

$$\left(\begin{array}{l} (p_{li}^{i,j}, p_{lil}^{i,j}), \quad i = \overline{1, k}, \quad j = \overline{1, k+1}; \\ (p_{lo}^{i,j}, p_{lol}^{i,j}), \quad i = \overline{1, k}, \quad j = \overline{1, k+1}; \\ (p_{4i}^{i,j}, p_{4il}^{i,j}), \quad i = \overline{1, k+1}, \quad j = \overline{1, k}; \\ (p_{4o}^{i,j}, p_{4ol}^{i,j}), \quad i = \overline{1, k+1}, \quad j = \overline{1, k}; \\ (p_{b1}^{i,j}, p_{b2}^{i,j}, p_{b3}^{i,j}, p_{b4}^{i,j}, p_{bl}^{i,j}), \quad i = \overline{1, k}, \quad j = \overline{1, k}; \\ (((p_{li}^{i,j}, p_{lo}^{i,j}, p_{4i}^{i,j}, p_{4o}^{i,j}, p_{b1}^{i,j}, p_{b2}^{i,j}, p_{b3}^{i,j}, p_{b4}^{i,j}), \quad i = \overline{1, k}, \quad j = \overline{1, k}), \\ \quad \quad \quad ((p_{4i}^{i,k+1}, p_{4o}^{i,k+1}), \quad i = \overline{1, k}), \quad ((p_{li}^{k+1,j}, p_{lo}^{k+1,j}), \quad j = \overline{1, k})) \\ (((p_{lil}^{i,j}, p_{lol}^{i,j}, p_{4il}^{i,j}, p_{4ol}^{i,j}, p_{bl}^{i,j}), \quad i = \overline{1, k}, \quad j = \overline{1, k}), \\ \quad \quad \quad ((p_{4il}^{i,k+1}, p_{4ol}^{i,k+1}), \quad i = \overline{1, k}), \quad ((p_{lil}^{k+1,j}, p_{lol}^{k+1,j}), \quad j = \overline{1, k})) \end{array} \right) \quad (2)$$

The way of the solutions description is common enough for sparse vectors and especially for the Petri net theory. Only nonzero components are mentioned by the name of a corresponding place. The nonzero multiplier 1 is omitted; in case it is not the unit, the notation p^*x is used where x is the value of the invariant for place p . Such notation is adopted in the Tina software [9] which was used for obtaining the Petri net figures in this paper. A line of the matrix (2) gives us a set of lines according to the used indices i and j except the last two lines which contain variable number of components given by indices. The total number of solutions is $N_k^{n2pinv} = 5 \cdot k^2 + 4 \cdot k + 2$.

We did not manage to prove that the matrix (2) is the basis of nonzero solutions of the system (1) but it is possible to ground that each line of (2) is a solution of (1). And this fact allows the proof of p-invariance for the net $n2sk$.

Lemma 1. Each line of the matrix (2) is a solution of the system (1).

Proof. Let us substitute each parametric line of (2) into each parametric equation of the system (1). It gives us the correct statement. For instance, let us substitute the first line of (2)

$$(p_{li}^{i',j'}, p_{lil}^{i',j'}), \quad i' = \overline{1, k}, \quad j' = \overline{1, k+1};$$

into the second equation of (1)

$$x_{li}^{i,j} + x_{bl}^{i,j} = x_{lil}^{i,j} + x_{b2}^{i,j}, \quad i = \overline{1, k}, \quad j = \overline{1, k}.$$

We obtain:

– when $i' \neq i$ or $j' \neq j$: $0 + 0 = 0 + 0$ and further $0 = 0$;

– when $i' = i$ and $j' = j$: $1 + 0 = 1 + 0$ and further $1 = 1$.

In the same way all the 16×7 combinations may be checked.

Theorem 1. The net $n2sk$ is a p-invariant Petri net for an arbitrary natural number k .

Proof. Let us consider the sum of the sixth and seventh lines of the matrix (2) which represents the solutions of the system (1) according to Lemma 1:

$$\begin{aligned} & (((p_{li}^{i,j}, p_{lo}^{i,j}, p_{4i}^{i,j}, p_{4o}^{i,j}, p_{b1}^{i,j}, p_{b2}^{i,j}, p_{b3}^{i,j}, p_{b4}^{i,j}), \quad i = \overline{1, k}, \quad j = \overline{1, k}), \\ & \quad \quad \quad ((p_{4i}^{i,k+1}, p_{4o}^{i,k+1}), \quad i = \overline{1, k}), \quad ((p_{li}^{k+1,j}, p_{lo}^{k+1,j}), \quad j = \overline{1, k})) \end{aligned}$$

plus

$$\begin{aligned} & (((p_{lil}^{i,j}, p_{lol}^{i,j}, p_{4il}^{i,j}, p_{4ol}^{i,j}, p_{bl}^{i,j}), \quad i = \overline{1, k}, \quad j = \overline{1, k}), \\ & \quad \quad \quad ((p_{4il}^{i,k+1}, p_{4ol}^{i,k+1}), \quad i = \overline{1, k}), \quad ((p_{lil}^{k+1,j}, p_{lol}^{k+1,j}), \quad j = \overline{1, k})) \end{aligned}$$

equals to

$$\begin{aligned} & (((p_{li}^{i,j}, p_{lil}^{i,j}, p_{lo}^{i,j}, p_{lol}^{i,j}, p_{4i}^{i,j}, p_{4il}^{i,j}, p_{4o}^{i,j}, p_{4ol}^{i,j}, p_{b1}^{i,j}, p_{b2}^{i,j}, \\ & \quad p_{b3}^{i,j}, p_{b4}^{i,j}, p_{bl}^{i,j}), \quad i = \overline{1, k}, \quad j = \overline{1, k}), \\ & \quad \quad \quad ((p_{li}^{i,k+1}, p_{lil}^{i,k+1}, p_{lo}^{i,k+1}, p_{lol}^{i,k+1}), \quad i = \overline{1, k}), \\ & \quad \quad \quad ((p_{4i}^{k+1,j}, p_{4il}^{k+1,j}, p_{4o}^{k+1,j}, p_{4ol}^{k+1,j}), \quad j = \overline{1, k})). \end{aligned} \quad (3)$$

As all the $N_k^{n2p} = 13 \cdot k^2 + 8 \cdot k$ places are mentioned in this invariant, the Petri net $n2sk$ is a p -invariant net for an arbitrary natural number k . Moreover, as each component of (3) equals to the unit, the net $n2sk$ is a safe and bounded Petri net for an arbitrary natural number k .

As the p -invariance was proven for an arbitrary natural number k we say that the invariants of infinite Petri nets with the regular structure were studied.

The proof that (2) is a basis of the system (1) solutions is appreciated. But this fact was only grounded by the calculation experiments for the sequence $k = 1, \dots, 10$. Solutions given by (2) were compared with the basis obtained via the Adriana software [10] for the matrix structure with definite k .

3. T-invariants and Deadlocks Structure. For the calculation of t-invariants the same approach may be applied. It gains that the Petri net $n2sk$ is not t-invariant, but it is not a surprise because the modeled system is open as the terminal devices are not attached. The simplest way to prove it, is the consideration of the border places without the input arcs (places without the output arcs as well). So let us consider the net $nf2sk$ which is obtained of the net $n2sk$ by attaching the terminal devices nf represented in Fig. 2,b.

But due to the explosion of the basis even for a small enough $k = 3$, the general parametric solution was not constructed. This fact may be easily grounded by the consideration of all the consistent firing sequences of transitions. At first we prove that the net $nf2sk$ is t-invariant. For this purpose the consistent firing sequence that contains all the transitions is constructed. We create a transmission graph of the communication matrix. The graph is composed of the cells corresponding to the devices. The cells have the form shown in Fig. 4.

Each arc of the graph corresponds to firing a pair of transitions supplying the movement of a packet to the corresponding port. For instance, the arc $(p1i, p4o)$ represents the sequence $t1i4, t4o$ and so on. For the graph shown in Fig. 4,b the following loop may be constructed, which contains all the arcs:

$p1i, p2o, p2i, p4o, p4i, p3o, p3i, p1o, p1i, p4o, p4i, p2o, p2i, p3o, p3i, p4o, p4i, p1o, p1i, p3o, p3i, p2o, p2i, p1o$.

This loop corresponds to the following firing sequence of transitions

$t1i2, t2o, tfi-r, tfo-r, t2i4, t4o, tfi-l, tfo-l, t4i3, t3o, tfi-d, tfo-d, t3i1, t1o, tfi-u, tfo-u, t1i4, t4o, tfi-l, tfo-l, t4i2, t2o, tfi-r, tfo-r, t2i3, t3o, tfi-d, tfo-d, t3i4, t4o, tfi-l, tfo-l, t4i1, t1o, tfi-u, tfo-u, t1i3, t3o, tfi-d, tfo-d, t3i2, t2o, tfi-r, tfo-r, t2i1, t1o, tfi-u, tfo-u$,

which contains each transition at least once. So the net $nf2s1$ is a t -invariant and, moreover, consistent Petri net.



a) without terminal devices ($n2s1$) b) with attached terminal devices ($nf2s1$)
Figure 4 – The transmission graph of a communication device

The cells are gathered into the matrix and supplied with the arcs which correspond to the actions of terminal devices for the net $nf2sk$. An example of the graph for $k = 2$ is represented in Fig. 5,a.

Theorem 2. The net $nf2sk$ is a t -invariant Petri net for an arbitrary natural number k .

Proof. We prove the theorem in a constructive way using the structure of the transmission graph for the net $nf2sk$. We construct the consistent firing sequence that contains all the transitions of the net on the base of the loop of the transmission graph which contains all its arcs. Let us construct the main loop as the composition of loops on the following directions: horizontal, vertical, primary diagonal, collateral diagonal:

1) horizontal loops:

$$((p_{4i}^{i,j} \rightarrow p_{4i}^{i,j+1}, j = \overline{1, k}), p_{4i}^{i,k+1} \rightarrow p_{4o}^{i,k+1}, (p_{4o}^{i,j+1} \rightarrow p_{4o}^{i,j}, j = \overline{k, 1}), p_{4o}^{i,1} \rightarrow p_{4i}^{i,1}), i = \overline{1, k};$$

2) vertical loops:

$$((p_{1i}^{i,j} \rightarrow p_{1i}^{i+1,j}, i = \overline{1, k}), p_{1i}^{k+1,j} \rightarrow p_{1o}^{k+1,j}, (p_{1o}^{i+1,j} \rightarrow p_{1o}^{i,j}, i = \overline{k, 1}), p_{1o}^{1,j} \rightarrow p_{1i}^{1,j}), j = \overline{1, k};$$

3) primary diagonal loops:

3.1) left-bottom triangle:

$$((p_{4i}^{v+u-1,u} \rightarrow p_{1i}^{v+u,u}, p_{1i}^{v+u,u} \rightarrow p_{4i}^{v+u,u+1}, u = \overline{1, k-v}), p_{4i}^{k,k-v+1} \rightarrow p_{1i}^{k+1,k-v+1}, p_{1i}^{k+1,k-v+1} \rightarrow p_{1o}^{k+1,k-v+1}, p_{1o}^{k+1,k-v+1} \rightarrow p_{4o}^{k,k-v+1}, (p_{4o}^{v+u,u+1} \rightarrow p_{1o}^{v+u,u}, p_{1o}^{v+u,u} \rightarrow p_{4o}^{v+u-1,u}, u = \overline{k-v, 1}), p_{4o}^{v,1} \rightarrow p_{4i}^{v,1}), v = \overline{1, k};$$

3.2) right-upper triangle:

$$((p_{li}^{u,v+u-1} \rightarrow p_{4i}^{u,v+u}, p_{4i}^{u,v+u} \rightarrow p_{li}^{u+1,v+u}, u = \overline{1, k-v}); p_{li}^{k-v+1,k} \rightarrow p_{4i}^{k-v+1,k+1}; p_{4i}^{k-v+1,k+1} \rightarrow p_{4o}^{k-v+1,k+1}; p_{4o}^{k-v+1,k+1} \rightarrow p_{lo}^{k-v+1,k}; (p_{lo}^{u+1,v+u} \rightarrow p_{4o}^{u,v+u}, p_{4o}^{u,v+u} \rightarrow p_{lo}^{u,v+u-1}, u = \overline{k-v, 1}); p_{lo}^{1,v} \rightarrow p_{li}^{1,v}), v = \overline{1, k};$$

4) collateral diagonal loops:

4.1) left-upper triangle:

$$((p_{4i}^{v-u+1,u} \rightarrow p_{li}^{v-u+1,u}, p_{li}^{v-u+1,u} \rightarrow p_{4i}^{v-u,u+1}, u = \overline{1, v-1}), p_{4i}^{1,v} \rightarrow p_{lo}^{1,v}, p_{lo}^{1,v} \rightarrow p_{li}^{1,v}, p_{li}^{1,v} \rightarrow p_{4o}^{1,v}, (p_{4o}^{v-u,u+1} \rightarrow p_{lo}^{v-u+1,u}, p_{lo}^{v-u+1,u} \rightarrow p_{4o}^{v-u+1,u}, u = \overline{v-1, 1}), p_{4o}^{v,1} \rightarrow p_{4i}^{v,1}), v = \overline{1, k};$$

4.2) right-bottom triangle:

$$(p_{lo}^{k-u+2,v+u-1} \rightarrow p_{4i}^{k-u+1,v+u}, (p_{4i}^{k-u+1,v+u} \rightarrow p_{lo}^{k-u+1,v+u}, u = \overline{1, k-v}), p_{lo}^{v+1,k} \rightarrow p_{4i}^{v,k+1}, p_{4i}^{v,k+1} \rightarrow p_{4o}^{v,k+1}, p_{4o}^{v,k+1} \rightarrow p_{li}^{v+1,k}, (p_{li}^{k-u+1,v+u} \rightarrow p_{4o}^{k-u+1,v+u}, p_{4o}^{k-u+1,v+u} \rightarrow p_{li}^{k-u+1,v+u-1}, u = \overline{k-v, 1}), p_{li}^{k+1,v} \rightarrow p_{lo}^{k+1,v}), v = \overline{1, k}.$$

On the described loops, firing sequences of transitions may be unambiguously constructed. For instance, the loops for the right-bottom triangle have the following form:

$$((t_{3i2}^{k-u+1,v+u-1}, t_{2o}^{k-u+1,v+u-1}, t_{4i1}^{k-u,v+u}, t_{1o}^{k-u,v+u}, u = \overline{1, k-v}), t_{3i2}^{v,k}, t_{2o}^{v,k}, t_{fi-r}^v, t_{fo-r}^v, t_{2i3}^{v,k}, t_{3o}^{v,k}, (t_{li4}^{k-u,v+u}, t_{4o}^{k-u,v+u}, t_{2i3}^{k-u+1,v+u-1}, t_{3o}^{k-u+1,v+u-1}, u = \overline{k-v, 1}), t_{fi-d}^v, t_{fo-d}^v), v = \overline{1, k}.$$

It is easy to check that the sum of all the firing sequences corresponding to the described loops contains each transition of the net $nf2sk$ at least once and preserves the initial marking. So the net $nf2sk$ is a t -invariant and, moreover, consistent Petri net for an arbitrary natural number k .

In spite of the fact that the Petri net $nf2sk$ is t -invariant and provides the transmission of packets among each pair of terminal devices with redundancy, it contains deadlocks. Deadlocks may occur in the pairs of communication devices but we are more interested in complex deadlocks involving an arbitrary number of communication devices.

Each pair of neighbor communication devices may fall into a local deadlock, for instance, when the device $R^{i,j}$ got l packets directed to the device $R^{i,j+1}$ and the device $R^{i,j+1}$ got l packets directed to the device $R^{i,j}$ and, moreover, the input and output buffers of their common port are occupied with the packets. Such a situation constitutes a t -dead marking for the transitions of both devices while other transitions of the net $nf2sk$ are potentially live.

In Fig. 3 the full deadlock for the net $nf2s2$ is shown. It involves all the four communication devices of the matrix.

For the description of the deadlocks structures of the net $nf2sk$, the graph of possible blockings shown in Fig. 5,b is constructed.

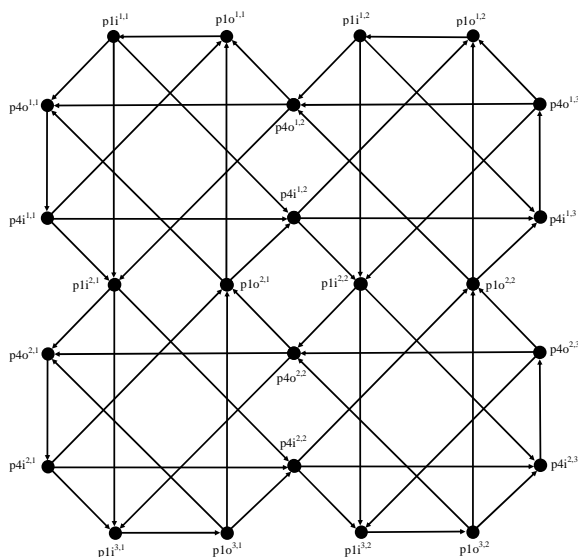

a) The transmission graph

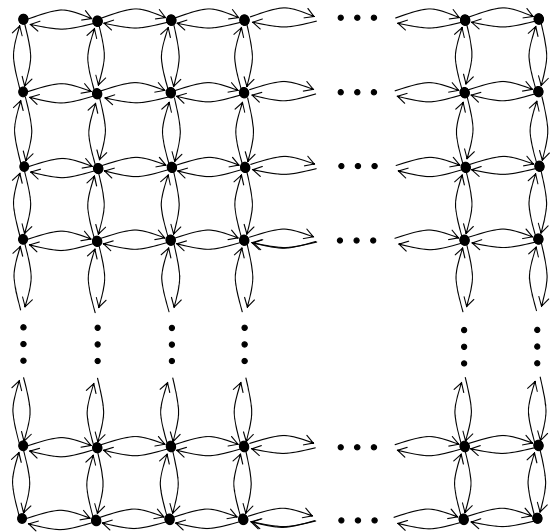

b) The graph of possible blockings

Figure 5 – Auxiliary graphs (examples for the net $nf2sk$)

The directed loops of the graph (Fig. 5,b) correspond to the deadlocks of the communication matrix $nf2sk$. Each arc connecting a pair of neighbor devices $R^{i,j}$, $R^{i',j'}$, $|i-i'|=1 \vee |j-j'|=1$ means that $R^{i,j}$ may block itself iff it got l packets directed to $R^{i',j'}$, its output buffer of the port connecting $R^{i,j}$ with $R^{i',j'}$ contains a packet and the device $R^{i',j'}$ is also blocked. We may construct a simple chain of arcs and the real deadlock occurs when it is closed in a loop. So deadlocks of the communication matrix may be described as loops of the graph of possible deadlocks. A full deadlock involving all the devices (and all the transitions) occurs when the loop contains all the devices in the matrix. Let us notice that it requires at least $(l+1) \cdot k^2$ packets which should be provided by the terminal devices. Such a deadlock may be easily constructed for an even k using, for instance, the detours of the graph shown in Fig. 6,a.



Figure 6 – The detours of the graphs of possible blockings

For an odd k , the loop may contain only $k^2 - 1$ devices but in this case we could make one device isolated by the loop that yields to the full deadlock. So the structure of the deadlocks is more complicated because, besides the deadlock caused by a cycle of blockings, isolated communication devices may occur with all the four neighbors belonging to the cycle. This case is rather simple for $k=3$ and illustrated with a full deadlock instance for $k=7$ shown in Fig. 6,b.

In spite of the fact that rather sophisticated square communication matrices were studied, the described deadlocks in the cycles of blockings and isolations are hard-nosed for real-life communication graphs where devices with the compulsory buffering are used. We believe that these deadlocks may be purposely inflicted by the specially situated generators of the peculiar traffic. In real-life networks, the blocking of the devices is overcome with the time-out mechanisms causing the cleaning of the buffers but it leads to a considerable fall of network performance as soon as the situation is repeated by the special generators of perilous traffic.

Thus, in the present paper, the technique of the linear invariants calculation for infinite Petri nets with the regular structure was presented. The technique was studied on the example of a communication matrix of an arbitrary size but it seems that the obtained results might be generalized for an arbitrary structure as well.

The application of the technique allowed the verification of the telecommunication protocols, involving an arbitrary number of communicating devices. The modeled telecommunication device constitutes a generalized router/switch with the compulsory buffering of the packets. Such positive properties of the communication structure as safeness and consistency were obtained using the linear invariants of infinite Petri nets.

It was grounded that the compulsory buffering of the packets inevitably leads to possible blockings of communicating devices. The structure of the complex deadlocks involving an arbitrary number of communicating devices caused by both the cycle of blockings and the isolation was studied.

Though in real-life networks the deadlocks are overcome by the cleaning of the buffers via the time-out mechanism, it leads to a considerable decrease of the network performance and moreover might be inflicted by the ill-intentioned traffic.

References

1. *Berthelot G.* Petri Nets Theory for the Correctness of Protocols / G. Berthelot, R.Terrat // IEEE Trans. on Communications. – 1982. – Vol. 30. – № 12. – P. 2497-2505.
2. *Diaz M.* Modelling and Analysis of Communication and Cooperation Protocols Using Petri Net Based Model / M. Diaz // Computer Networks. – 1982. – № 6. – P. 419-441.

3. *Zaitsev D.A.* Functional Petri Nets / Zaitsev D.A. – Universite Paris-Dauphine, Cahier du Lamsade 224, Avril 2005. – 62 p. (www.lamsade.dauphine.fr/cahiers.html).
4. *Zaitsev D.A.* Verification of Ethernet protocols via parametric composition of Petri net / D.A. Zaitsev, I.D. Zaitsev // INCOM'2006: 12th IFAC/IFIP/IFORS/IEEE/IMS Symposium Information Control Problems in Manufacturing, may 17-19, 2006. – Saint-Etienne (France). – 2006. – P. 261-267.
5. *Shmeleva T.R.* Verification of switched Ethernet protocols using infinite Petri nets / T.R. Shmeleva // COMINFO'2007: Proceedings of Third International Scientific and Technical Conference – Modern Information and Communication Technologies, September 24-28, 2007. – Livadiya (Ukraine). – 2007. – P.161-163.
6. *Russell T.* Telecommunications Protocols, 2nd Edition. / Russell T. – McGraw-Hill, 2004. – 686 p.
7. *Zaitsev D.A.* Switched Ethernet Response Time Evaluation via Colored Petri Net Model / D.A. Zaitsev, T.R. Shmeleva // Proceedings of International Middle Eastern Multiconference on Simulation and Modelling, August 28-30, 2006. – Alexandria (Egypt). – 2006. – P. 68-77.
8. *Murata T.* Petri Nets: Properties, Analysis and Applications / T.Murata // Proceedings of the IEEE, April 1989. – Vol. 77. – P. 541-580.
9. *Berthomieu B.* The tool TINA - construction of abstract state space for Petri nets and Time Petri nets / B. Berthomieu, O.-P. Ribet, F. Vernadat // International Journal of Production Research. – 2004. – Vol. 42, №14. – P. 2741-2756.
10. *Zaitsev D.A.* On realization of compositional algorithms of linear systems solution / D.A. Zaitsev // Upravliayuschie systemi i mashini (Control systems and machines). – 2006. – №. 3. – P. 32-41. In Russ.